

● Features:

1. Emitted Color: Red, Green, Blue and White.
2. Lens Appearance: Water Clear.
3. 5.0x5.4x1.6mm standard package.
4. Suitable for all SMT assembly methods.
5. Compatible with infrared and vapor phase reflow solder process.
6. Compatible with automatic placement equipment.
7. This product doesn't contain restriction Substance, comply ROHS standard.
8. 256 level Color set.
9. High contrast.
10. Built-in support for continuous oscillation PWM output can be maintained static screen.
11. Its function will be automatically reset when power on and power off.
12. Single lane data transfer.
13. Transmission distance is beyond 10M.
14. Frequency of data signal : 800KHz

● Package Dimensions:

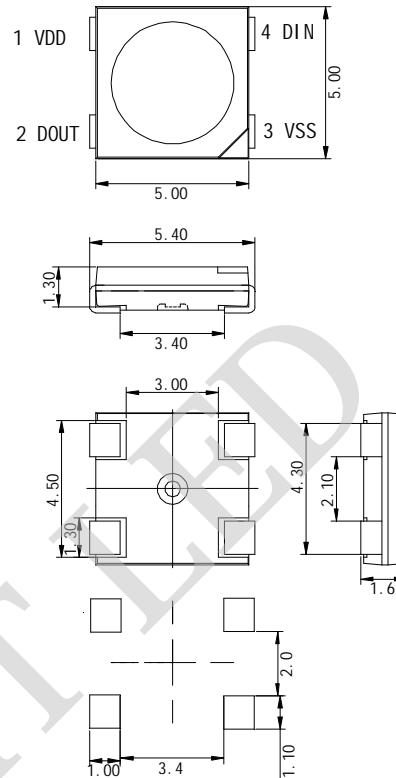

NOTES:

1. All dimensions are in millimeters (inches).
2. Tolerance is $\pm 0.10\text{mm}$ (0.004") unless otherwise specified.
3. Specifications are subject to change without notice.

● Applications:

1. Large LED Display.
2. Soft Light Bar.
3. Full Color Display.

● Absolute Maximum Ratings($T_a=25^\circ\text{C}$)

Parameter	Symbol	Range	Unit
Supply voltage	VDD	3.5~5.5	V
Input Voltage	V_i	-0.4~VDD+0.4	V
Operating Temperature	T_{opt}	-40~85	$^\circ\text{C}$
Storage Temperature	T_{stg}	-40~85	$^\circ\text{C}$
Soldering Temperature	T_{sol}	See Page 8	-



● Electrical characteristics(Ta=25°C)

Parameter	Symbol	Condition	Min.	Typ.	Max.	Unit
Supply Voltage	VDD	-	3.5	5.0	5.5	V
Input Voltage Level	VIH	DIN High Level	0.7*VDD	-	-	V
	VIL	DIN Low Level	-	-	0.3*VDD	V
Static current	IDD	VDD = 4.5V , Iout "OFF"	-	0.29	-	mA
R/G/B Constant Current	Iout	-	-	12	-	mA
Frequency of data signal	FDIN	-	-	800	-	KHz
Signal Transfer Delay Time	tPLH	DIN to DOUT	-	100	-	ns
Dout Conversion time	tPHL	-	-	100	-	ns
	tTLH	-	-	20	-	ns
	tTHL	-	-	10	-	ns

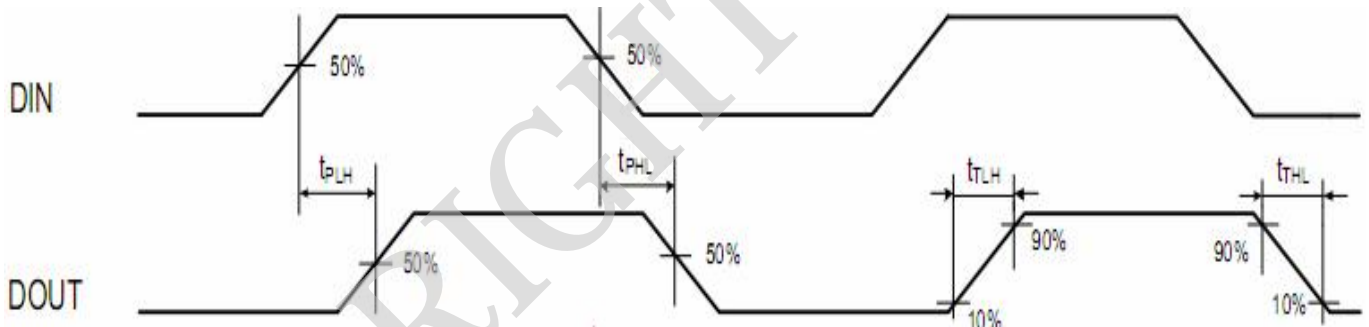

● Optical characteristics(Ta=25°C)

Parameter	Symbol	Condition	Min	Typ	Max.	Unit
Luminous Intensity	IV(R)	Iout=12mA	200	-	420	mcd
	IV(G)	Iout=12mA	700	-	1400	mcd
	IV(B)	Iout=12mA	180	-	360	mcd
	IV(W)	Iout=12mA	-	2000	-	mcd
Dominant Wavelength	WLD(R)	Iout=12mA	620	-	630	nm
	WLD(G)	Iout=12mA	520	-	530	nm
	WLD(B)	Iout=12mA	460	-	475	nm
View Angle	2θ 1/2	Iout=12mA	-	120	-	deg



Color Temperature Bin Limits

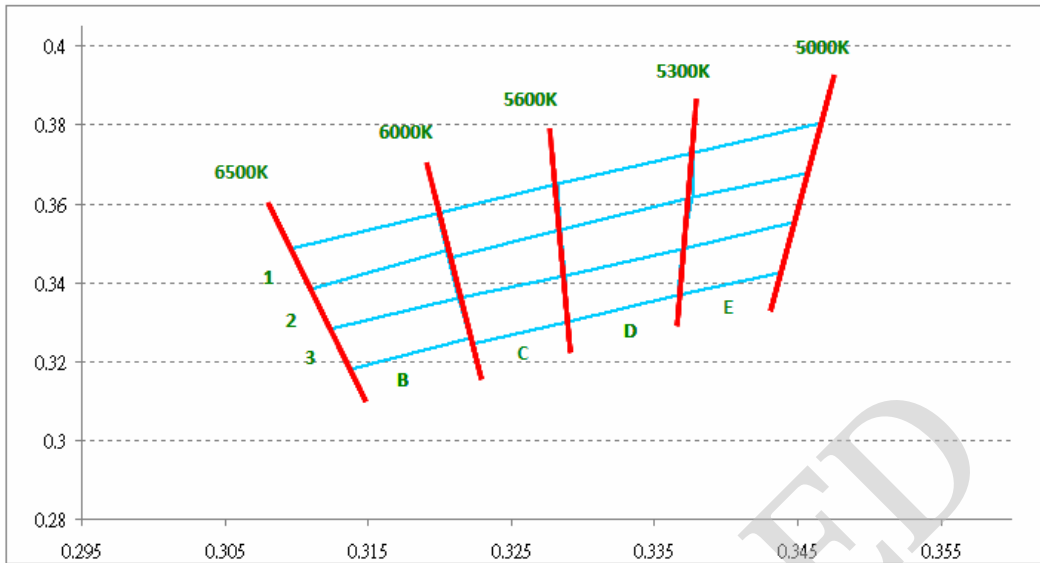

BIN	CCT(K)	Chromaticity Coordinates					
		x	y	x	y	x	y
B-1	6000-6500K	x	0.3205	0.3109	0.3095	0.3198	0.3205
		y	0.3481	0.3385	0.3485	0.3575	0.3481
B-2		x	0.3213	0.3123	0.3109	0.3205	0.3213
		y	0.3360	0.3282	0.3385	0.3481	0.3360
B-3		x	0.3221	0.3137	0.3123	0.3213	0.3221
		y	0.3261	0.3180	0.3282	0.3360	0.3261
C-1	5600-6000K	x	0.3284	0.3207	0.3198	0.3282	0.3284
		y	0.3535	0.3462	0.3575	0.3650	0.3535
C-2		x	0.3287	0.3213	0.3207	0.3284	0.3287
		y	0.3417	0.3360	0.3462	0.3535	0.3417
C-3		x	0.3289	0.3222	0.3213	0.3287	0.3289
		y	0.3302	0.3243	0.3360	0.3417	0.3302
D-1	5300-5600K	x	0.3376	0.3284	0.3282	0.3377	0.3376
		y	0.3616	0.3535	0.3650	0.3730	0.3616
D-2		x	0.3369	0.3287	0.3284	0.3376	0.3369
		y	0.3485	0.3417	0.3535	0.3616	0.3485
D-3		x	0.3366	0.3289	0.3287	0.3369	0.3366
		y	0.3369	0.3302	0.3417	0.3485	0.3369
E-1	5000-5300K	x	0.3456	0.3376	0.3377	0.3466	0.3456
		y	0.3678	0.3616	0.3730	0.3806	0.3678
E-2		x	0.3447	0.3369	0.3376	0.3456	0.3447
		y	0.3553	0.3485	0.3616	0.3678	0.3553
E-3		x	0.3437	0.3366	0.3369	0.3447	0.3437
		y	0.3424	0.3369	0.3485	0.3553	0.3424

● Sequence Chart

Cascade method

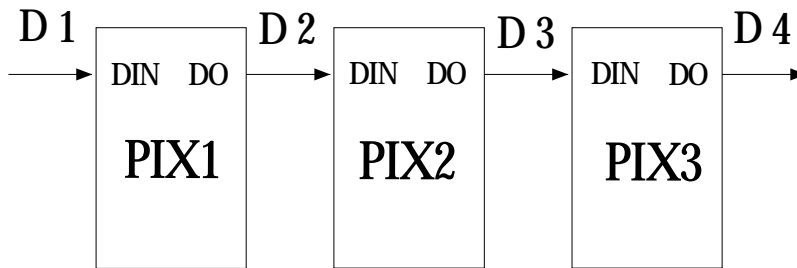

Input Code

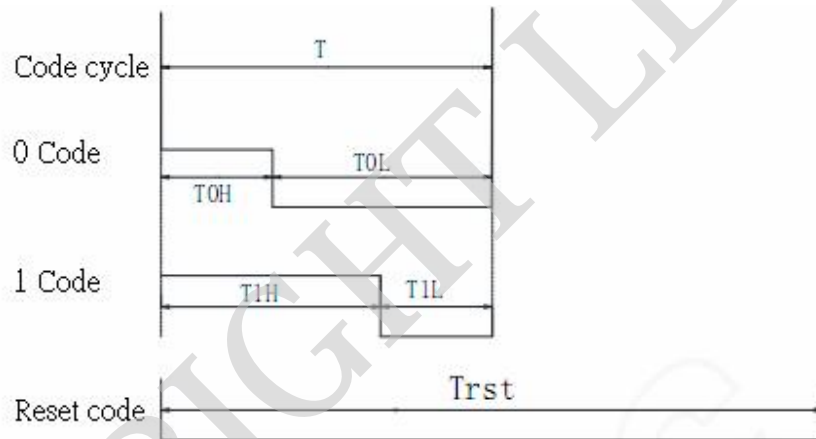

symbol	parameter	Min	tolerance	unit
T	Element cycle	1.2	-	us
T0H	0 Code, high level time	0.3	±0.05	us
T0L	0 Code, low level time	0.9	±0.05	us
T1H	1 Code, high level time	0.9	±0.05	us
T1L	1 Code, low level time	0.3	±0.05	us
Trst	Reset Code, low level time	>200	-	us

Note:1. When writing a program, the minimum code cycle requirement is 1.2us
 2. 0 code and 1 code low frequency time requirement is less than 20us

● The circuit diagram

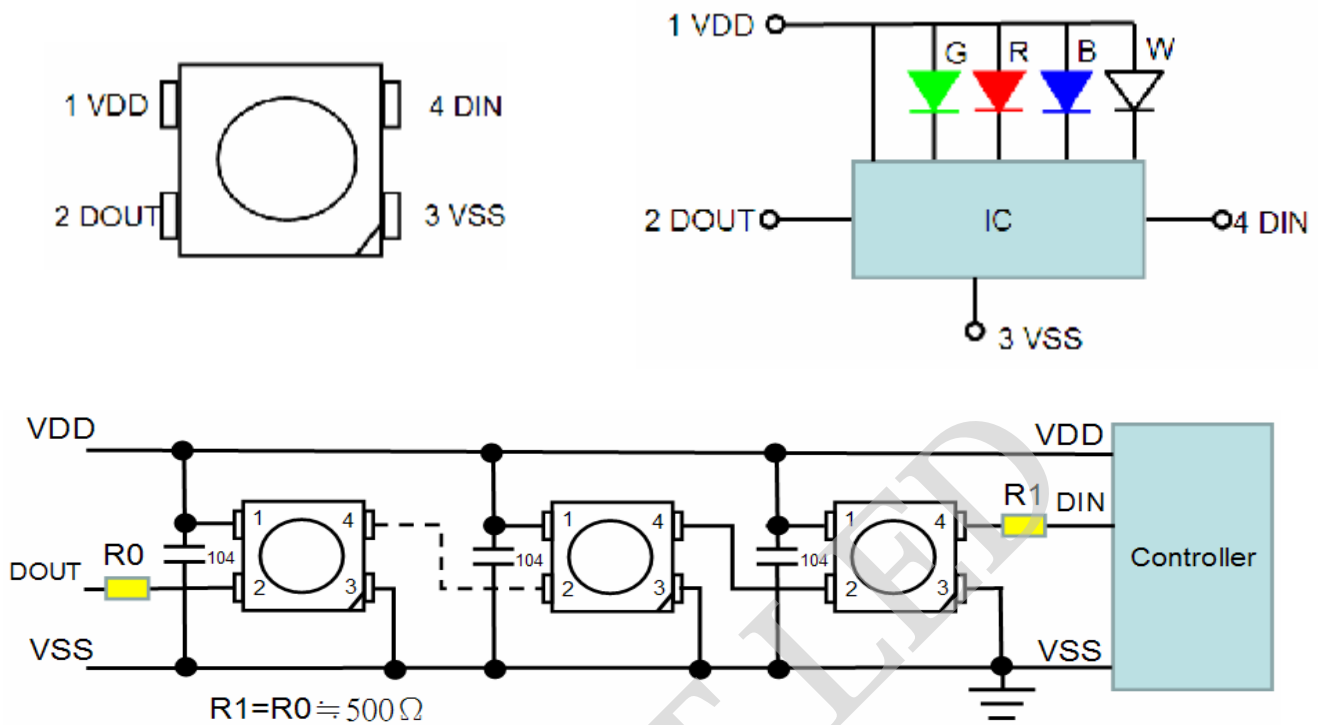

● Data transmission mode

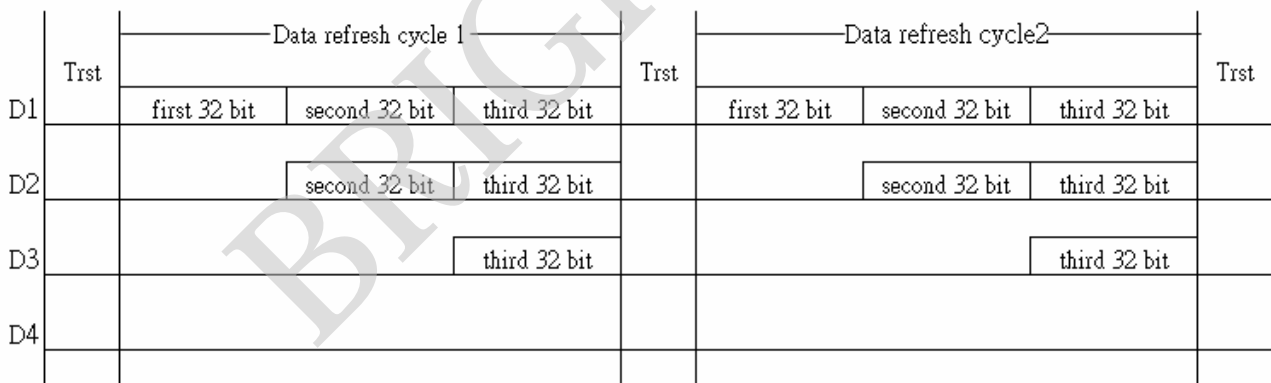

Note: D1 is the data sent by the MCU terminal, and D2, D3 and D4 are the data automatically reshaped and forwarded by the cascade circuit

G7	G6	G5	G4	G3	G2	G1	G0	R7	R6	R5	R4
R3	R2	R1	R0	B7	B6	B5	B4	B3	B2	B1	B0
W7	W6	W5	W4	W3	W2	W1	W0	-	-	-	-

Note: Follow the order of GRBW to send data and the high bit sent at first.

● Tapping and packaging specifications(Units: mm)

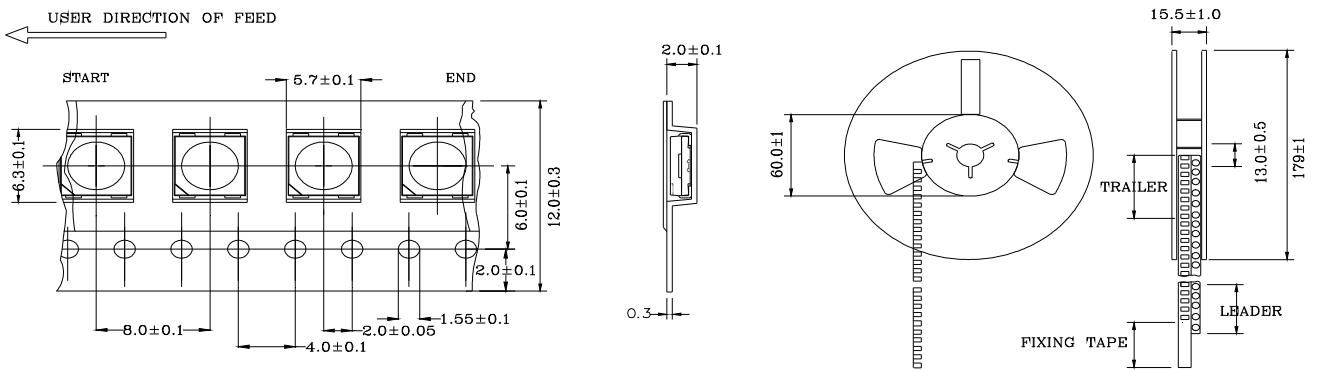

NOTE:1000 PCS PER REEL

● Package Method: (unit : mm)

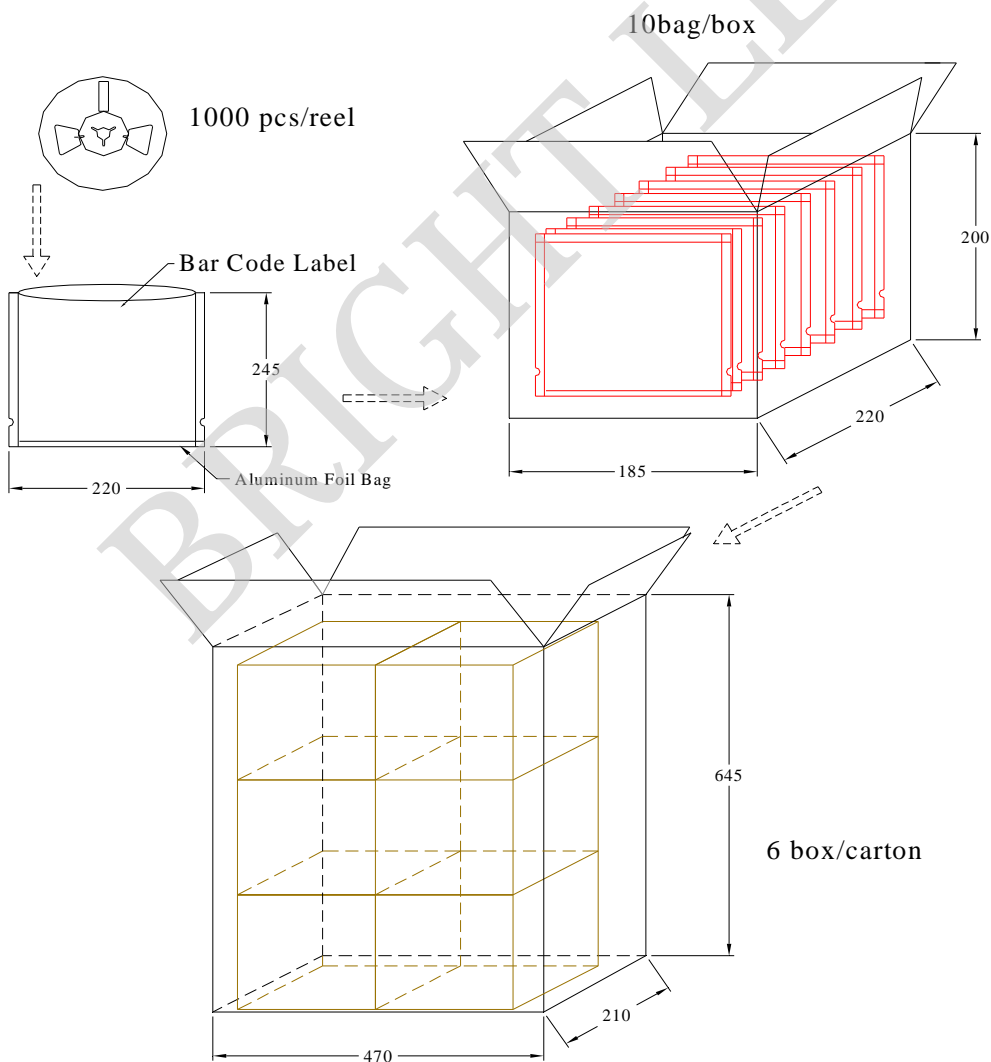



● Reliability Test

Classification	Test Item	Reference Standard	Test Conditions	Result
Endurance Test	Operation Life	MIL-STD-750:1026 MIL-STD-883:1005 JIS-C-7021 :B-1	VDD=5V , Iout =12mA Ta=Under room temperature Test time=1,000hrs	0/20
	High Temperature High Humidity Storage	MIL-STD-202:103B JIS-C-7021 :B-11	Ta=+65°C±5°C RH=90%-95% Test time=240hrs	0/20
	High Temperature Storage	MIL-STD-883:1008 JIS-C-7021 :B-10	High Ta=+85°C±5°C Test time=1,000hrs	0/20
	Low Temperature Storage	JIS-C-7021 :B-12	Low Ta=-35°C±5°C Test time=1,000hrs	0/20
Environmental Test	Temperature Cycling	MIL-STD-202:107D MIL-STD-750:1051 MIL-STD-883:1010 JIS-C-7021 :A-4	-35°C ~ +25°C ~ +85°C ~ +25°C 60min 20min 60min 20min Test Time=5cycle	0/20
	Thermal Shock	MIL-STD-202:107D MIL-STD-750:1051 MIL-STD-883:1011	-35°C±5°C ~+85°C±5°C 20min 20min Test Time=10cycle	0/20
	Solder Resistance	MIL-STD-202:201A MIL-STD-750:2031 JIS-C-7021 :A-1	Preheating : 140°C-160°C, within 2 minutes. Operation heating : 260°C (Max.), within 10seconds. (Max.)	0/20

● Judgment criteria of failure for the reliability

Measuring items	Symbol	Measuring conditions	Judgment criteria for failure
Luminous intensity	Iv (mcd)	VDD=5V Iout =12mA	Below S ¹ X0.5

Note: 1. U means the upper limit of specified characteristics. S means initial value.

2. After each test, remove test pieces, wait for 2 hours and test pieces have returned to ambient temperature, then take next measurement.

● IR-Reflow

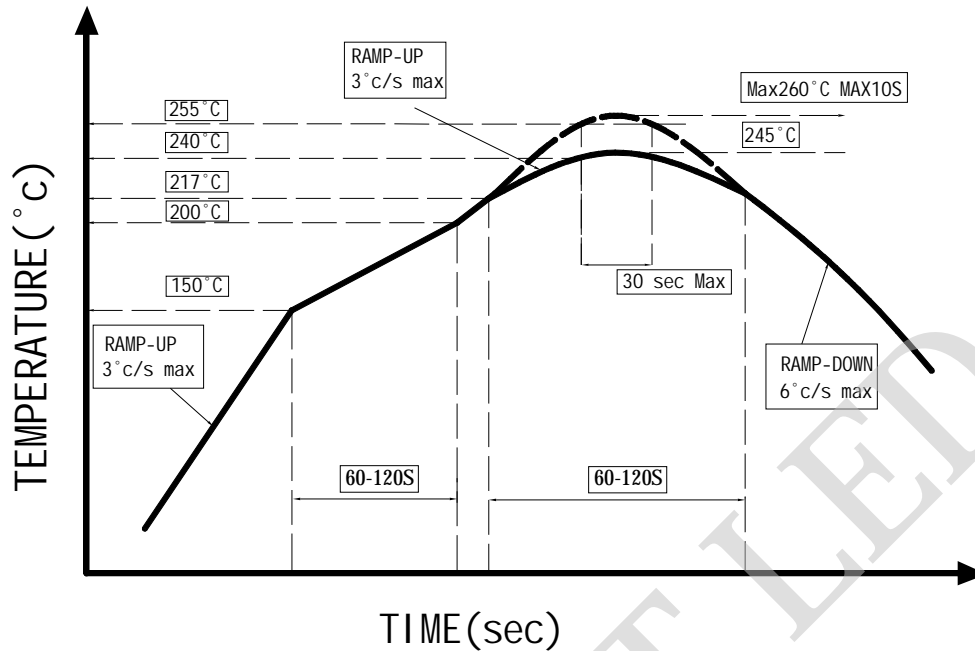

- 1、 Avoid any external stress applied to the resin while the LEDs are at high temperature, especially during soldering.
- 2、 Avoid rapid cooling or any excess vibration during temperature ramp-down process
- 3、 Although the soldering condition is recommended above, soldering at the lowest possible temperature is feasible for the LEDs

● IRON Soldering

350°C Within 3 sec, one time only.

● Handling Precautions

Compare to epoxy encapsulant that is hard and brittle, silicone is softer and flexible. Although its characteristic significantly reduces thermal stress, it is more susceptible to damage by external mechanical force.

As a result, special handling precautions need to be observed during assembly using silicone encapsulated LED products. Failure to comply might lead to damage and premature failure of the LED.

1. Handle the component along the side surfaces by using forceps or appropriate tools. (pic.1)
2. Do not directly touch or handle the silicone lens surface. It may damage the internal circuitry. (pic.2, pic.3)
3. Do not stack together assembled PCBs, containing exposed LEDs. Impact may scratch the silicone lens or damage the internal circuitry. (pic.4)
4. The outer diameter of the SMD pickup nozzle should not exceed the size of the LED to prevent air leaks. The inner diameter of the nozzle should be as large as possible. (pic.5)
5. A pliable material is suggested for the nozzle tip to avoid scratching or damaging the LED surface during pickup. (pic.5)
6. The dimensions of the component must be accurately programmed in the pick-and-place machine to insure precise pickup and avoid damage during production. (pic.5)

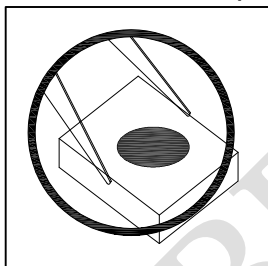

Pic.1

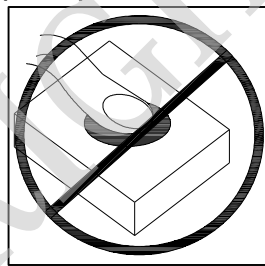

Pic.2

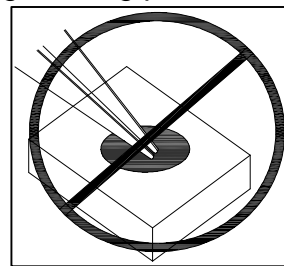

Pic.3

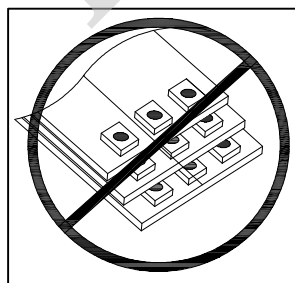

Pic.4

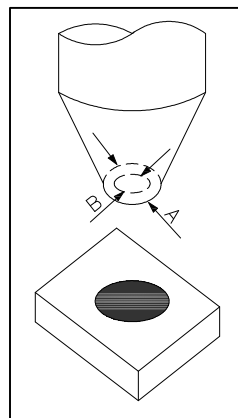

Pic.5



BRIGHT LED ELECTRONICS CORP.

BB-HGRBW32K-A-TRB-4

● Notes for designing:

Care must be taken to provide the current limiting resistor in the circuit so as to drive the LEDs within the rated figures. Also, caution should be taken not to overload LEDs with instantaneous voltage at the turning ON and OFF of the circuit.

When using the pulse drive care must be taken to keep the average current within the rated figures. Also, the circuit should be designed so as to be subjected to reverse voltage when turning off the LEDs.

● Storage:

In order to avoid the absorption of moisture, it is recommended to solder LEDs as soon as possible after unpacking the sealed envelope.

If the envelope is still packed, to store it in the environment as following:

- (1) Temperature : 5°C-30°C (41°F) Humidity : RH 60% Max.
- (2) After this bag is opened, devices that will be applied to infrared reflow, vapor-phase reflow, or equivalent soldering process must be:
 - a. Completed within 24hours.
Stored at less than 20% RH.
- (3) Devices require baking before mounting, if:
 - 2a or 2b is not met.
- (4) If baking is required, devices must be baked under below conditions:
48 hours at 60°C±5°C.

Package and Label of Products:

- (1) Package: Products are packed in one bag of 1000 pcs (one taping reel) and a label is attached on each bag.
- (2) Label:

